

# 6'x8' Dock Section

For Non-commercial and Non-public Applications  
Use with Pipe or Post Legs

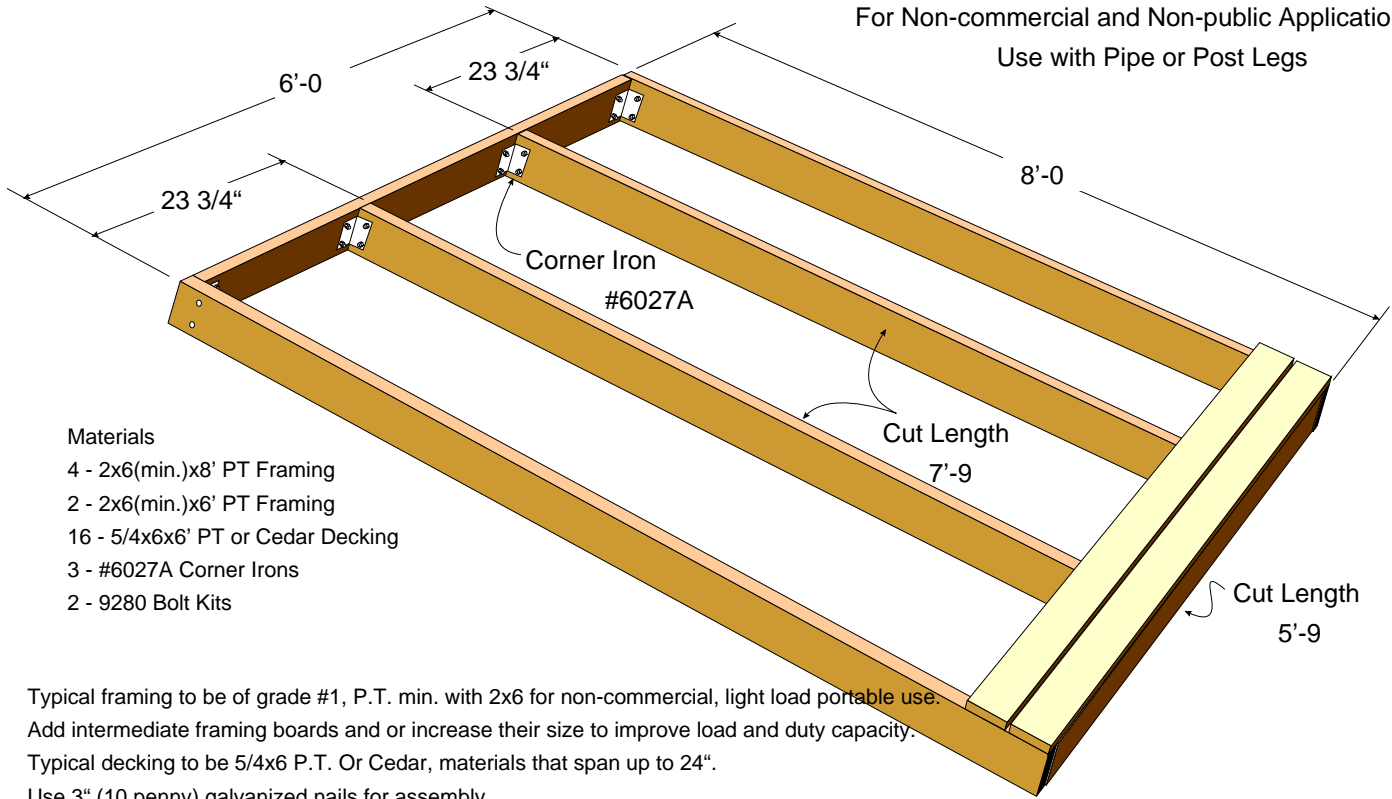

- Materials**
- 4 - 2x6(min.)x8' PT Framing
  - 2 - 2x6(min.)x6' PT Framing
  - 16 - 5/4x6x6' PT or Cedar Decking
  - 3 - #6027A Corner Irons
  - 2 - 9280 Bolt Kits

Typical framing to be of grade #1, P.T. min. with 2x6 for non-commercial, light load portable use.  
Add intermediate framing boards and or increase their size to improve load and duty capacity.  
Typical decking to be 5/4x6 P.T. Or Cedar, materials that span up to 24".  
Use 3" (10 penny) galvanized nails for assembly.  
Decking to be cut 6' flush to frame to prevent snagging with boats and gear.  
Router along the ends of the deck boards with a 3/8" radius to soften edges and reduce splinters.  
Use typical 1/2" spacing between deck boards to avoid leaf and other debris trapping.  
For sections that will connect together with J-Brackets (#9067), reinforce the butt joints on one end as shown.  
For reinforcing butt joints that could pull apart at the nails, use the Corner Iron (#6027A) with carriage bolts.

**PROVISIONS FOR COMPOSITE DECKS:**  
Composite decking or Thru-flow TM requires additional support, therefore, 2x4s can be added between the main stringers (shown below) or just add more main stringers reducing the decking span to 16" or less.

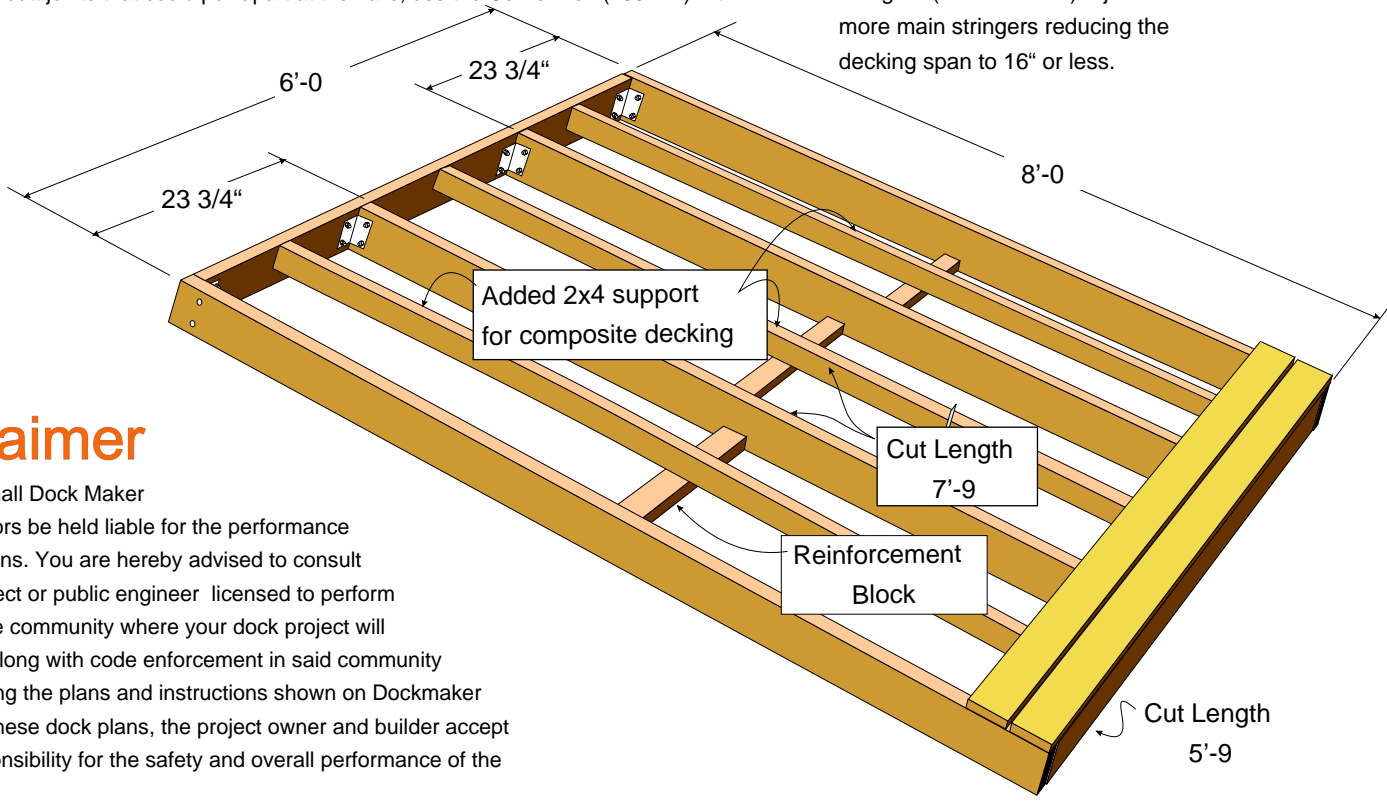

## Disclaimer

In no event shall Dock Maker or its proprietors be held liable for the performance of these designs. You are hereby advised to consult with an architect or public engineer licensed to perform services in the community where your dock project will be installed, along with code enforcement in said community before following the plans and instructions shown on Dockmaker. By following these dock plans, the project owner and builder accept the sole responsibility for the safety and overall performance of the design.